

# SMD 1B / SMD 2 / SMD 3 flow meters

Modular design for oil circulating lubrication systems with gearwheel-type flow indicator and bypass system

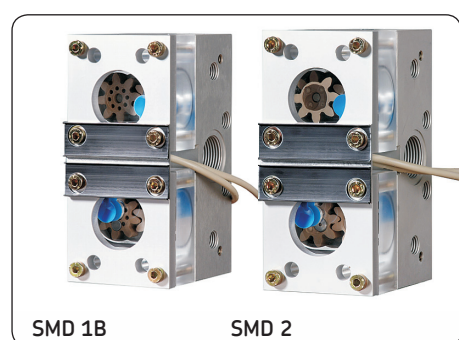

## Application

Flow meters of the SMD 1B, SMD 2 and SMD 3 series are mainly used in oil circulating lubrication systems for paper machines. They stand out especially for their reliability, easy maintenance and flexibility.

## Advantages

- Modular design to adapt the lubrication system to machines and systems anytime.
- Flow adaption by means of an adjustment valve. The oil flow is continuously adjustable even while the system is running.
- The setting range of the flow meters are:
  - SMD 1B from **0,05** to **1,0 l/min.**
  - SMD 2 by using a fine adjustment valve from **0,1** to **4,4 l/min,** by using a coarse adjustment valve from **4** to **8,0 l/min.**
  - SMD 3 from **4** to **40 l/min.**
- Electric pulse monitoring (NAMUR switch). The combination of visual and electrical monitoring helps to provide the best possible flow monitoring.
- User-friendliness thanks to a bypass system. If any servicing work should become necessary, it can be carried out without changing the setting of the adjustment valve and without interrupting the lubricant supply.
- Optional flushing block for easy service.

## Table of contents

General.....	2
Assembly of SMD .....	2
Flow adjustment .....	3
Gear wheel flow indicator .....	3
Bypass valve closed (operating position) .....	3
Bypass valve open (service position) .....	3
Electric supply for the gearwheel-type flow indicator .....	3
Characteristics of the flow meter.....	4
Basic dimensions for the flow meter .....	5
Examples of SMD in a stainless steel cabinet .....	6
Order list.....	7
Leaflets.....	8

## Assembly of SMD

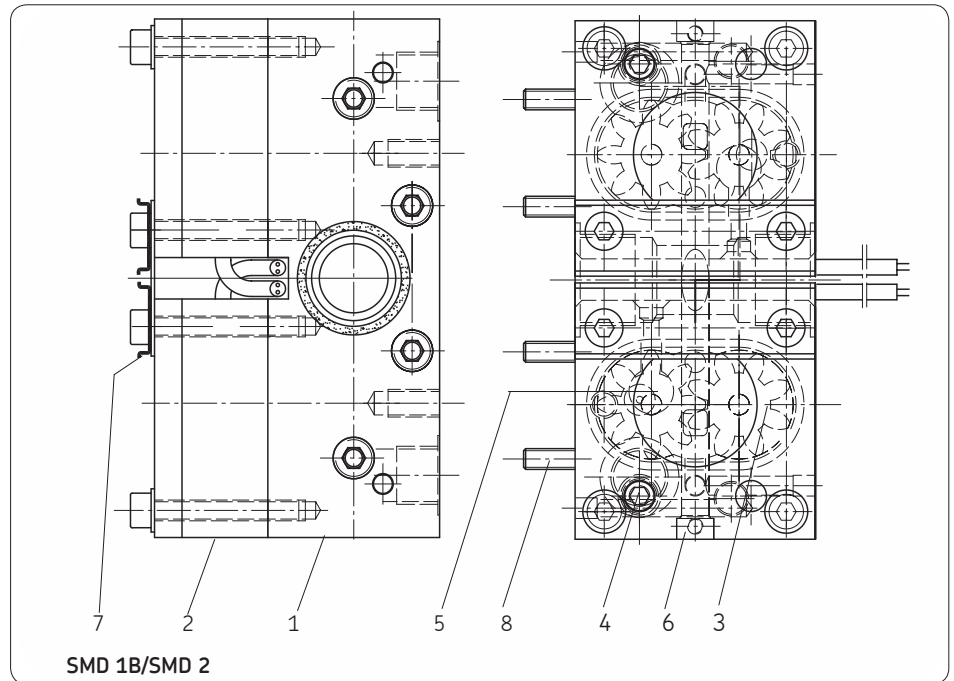

## General

The individual flow meters are designed to either divide the oil flow of the main line into defined flows or shut-off valves if necessary. Restrictor valve systems have proved to be reliable and flexible especially in paper-machines that often have several hundred lubricating points. Those systems are used whenever minor adjustments and corrections of the lubricant supply must be performed while the machine is running. For better serviceability and reduced down-time, a bypass function is integrated into the SMD1B, SMD 2 and SMD 3 flow meters. This makes it possible to service the flow meters without changing the adjustment and with no impact on the oil flow. The bypass function is part of the SMD 1B, SMD 2 and SMD 3 scope of supply.

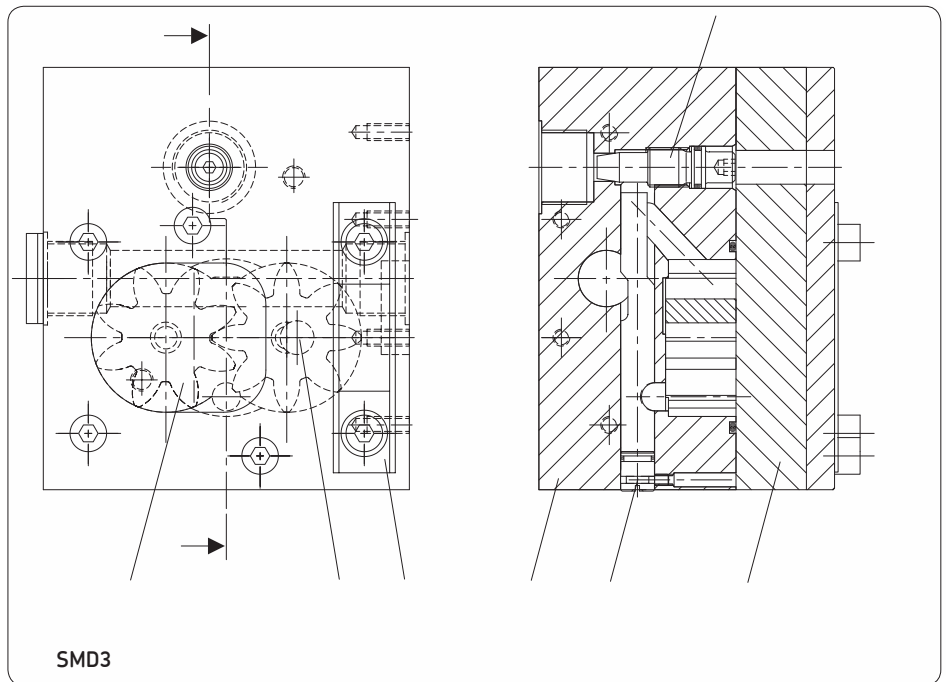

### Position Description

- 1 Housing
- 2 Plexiglas lid
- 3 GRP gear wheels
- 4 Adjustmant valve
- 5 NAMUR switch (electr. pulse monitoring)
- 6 Bypass valve
- 7 Cable duct cover/Plate holder
- 8 Connection screw for modular design

See important product usage information on the back cover.

### Flow adjustment

The lubricant coming from the supply line flows from the inlet of the housing into the wheel chamber and over the gear wheels to the throttle. The flow is regulated by means of the adjustment valve (very fine, fine or coarse). After having passed the adjustment valve, the dosed lubricant flows to the outlet of the housing.

### Gearwheel flow indicator

The lubricant coming from the supply line flows from the inlet of the housing into the wheel chamber and over the gear wheels to the adjustment valve. This flow generates a rotation of the gear wheels. A NAMUR switch installed above one of the gear wheels detects the rotation (pulse detection) of the gear wheels. The number of pulses as an equivalent of the flow (flow rate) depends on the position of the adjustment valve.

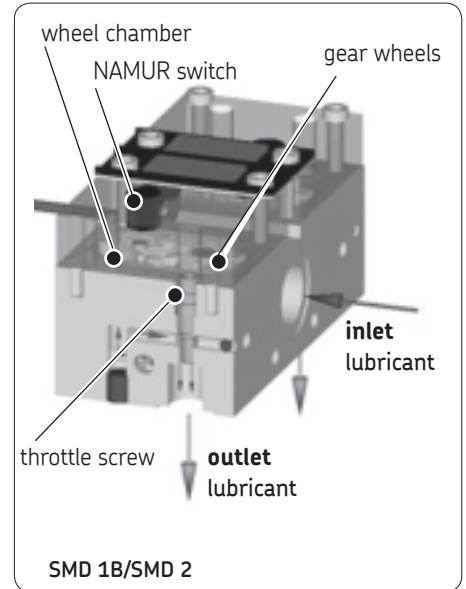

### Bypass valve closed (operating position)

The lubricant flows from the inlet through the gear wheel chamber and over the adjustment valve to the outlet.

### Bypass valve open (service position)

No lubricant passes the wheel chamber. The oil flows across the adjustment valve directly to the lube point.

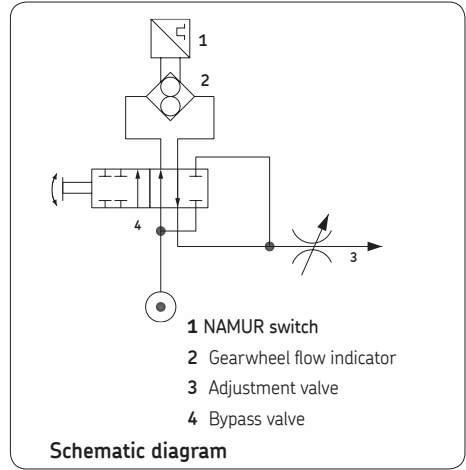
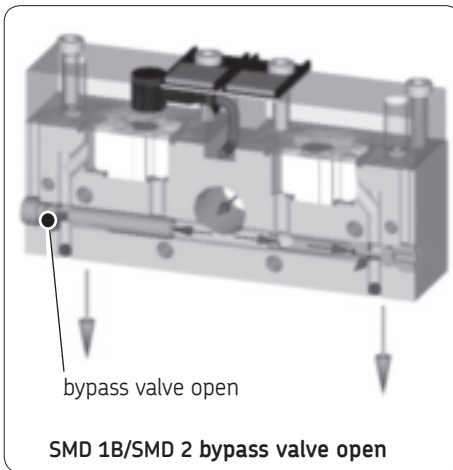
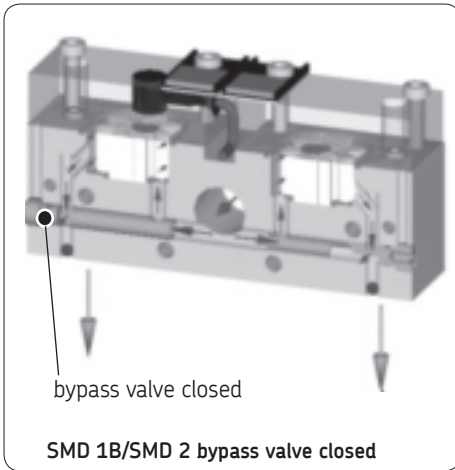

### Electric supply for the gear-wheel flow indicator

Connect electric leads according to the technical specifications and local regulations (DIN, VDE).

Connection cable for NAMUR switch  
white/power supply +  
brown/ground -

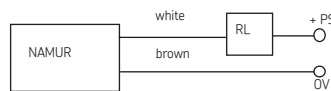

## Characteristics of the flow meter

### General

Type .....	adjusting valve
Mounting position.....	any
Material .....	SMD 1B; SMD2: anodized aluminium housing, transparent lid <sup>1)</sup> ; GRP gear wheels SMD 3 anodized aluminium housing; transparent lid <sup>1)</sup> ; GRP/aluminium gear wheels
Inlets .....	3/4" BSPP (1.1/16-12 UN <sup>3)</sup> )
Outlets .....	SMD 1B; SMD 2: 3/8" BSPP <sup>2)</sup> (9/16-18 UNF <sup>3)</sup> ) SMD 3 ..... 3/4" BSPP <sup>2)</sup> (1.1/16-12 UN <sup>3)</sup> )
Ambient temperature range .....	0 °C to + 70 °C (32°F to 158°F)
Number of outlets per module .....	SMD 1B; SMD2 = 2 SMD 3 = 1
Weight .....	SMD 1B; SMD 2 ... 1.70 Kg (3.75 lbs.) SMD 3 ..... 4.70 Kg (10.38 lbs.)

### Hydraulics

Working pressure .....	max. 16 bar (max. 232 psi)
Lubricant.....	Mineral oils and synthetic oils <sup>4)</sup>
Operating viscosity.....	50 to 650 mm <sup>2</sup> /s (50 to 650 cSt.)
Nominal flow per flow meter .....	SMD 1B 0.05 to 1.0 l/min (0.1 to 2.1 pts./min.); (Previous version SMD 1A: 0.05 to 0.25 l/min and 0.1 to 0.53 pts./min. respectively) SMD 2 0.1 to 8.0 l/min (0.21 to 16.91 pts./min.) SMD 3 4.0 to 40.0 l/min (8.45 to 84.53 pts./min.)
Specific flow .....	SMD 1B 2.6 ml/output signal per pulse (0.0055 pts./output signal per pulse)
.....	SMD 2 9.3 ml/output signal per pulse (0.0197 pts./output signal per pulse)
.....	SMD 3 39 ml/Output signal per pulse (0.0824 pts./output signal per pulse)

### Electrics

Characteristics of the NAMUR inductive proximity switch:

Nominal operating voltage .....	8.2 V
Operating voltage range .....	5 to 30 V DC
Attenuated power input .....	< 1 mA
Unattenuated power input .....	> 4 mA
Type of protection IP65 (comparable to NEMA 4)	

### Color code for adjustment valves:

Very fine throttle screw .....	SMD 1B blue (previous version SMD 1A green)
Fine throttle screw .....	SMD 2 red
Coarse throttle screw .....	SMD 2 yellow
.....	SMD 3 yellow

**Optional** .. connection block, shut off block, flushing port

1) = Plastic, clear; 2) = BSPP thread; 3) = SAE thread; 4) = except polyglycol

### Basic dimensions for the flow meter

#### SMD 1B; SMD 2

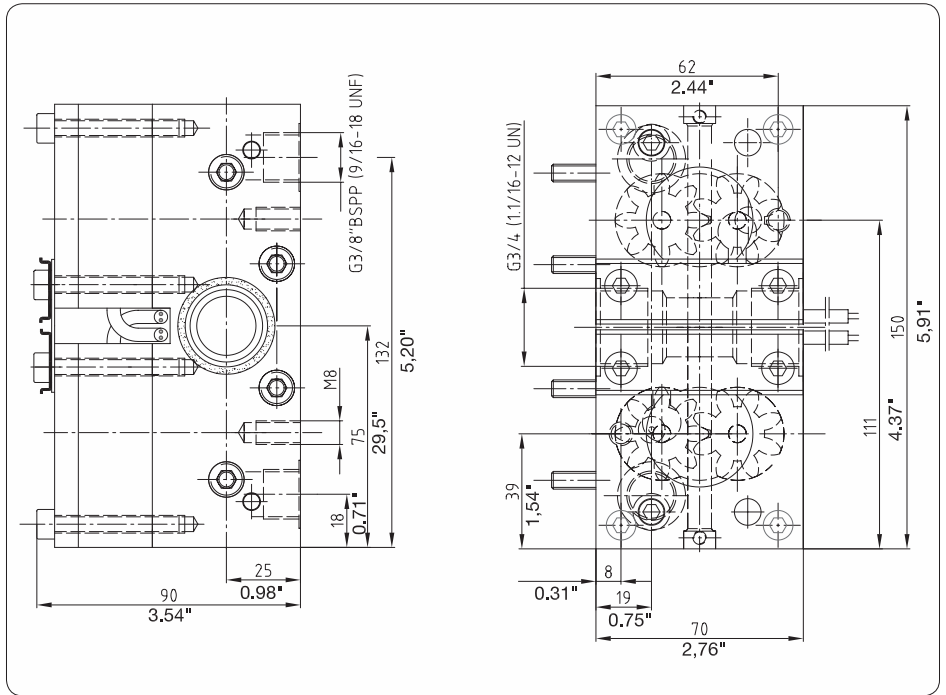
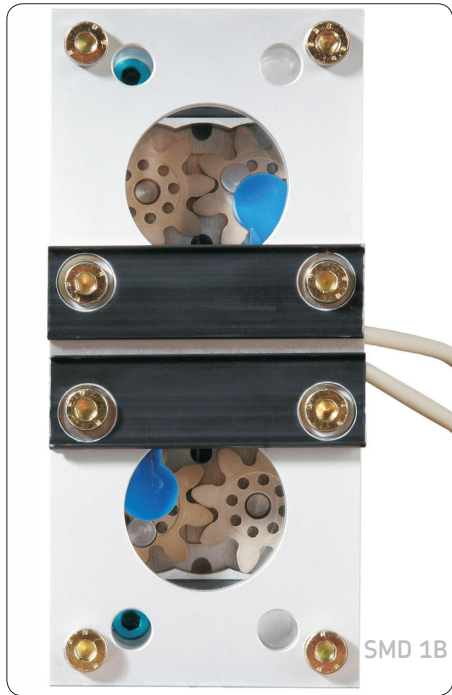

#### SMD 3

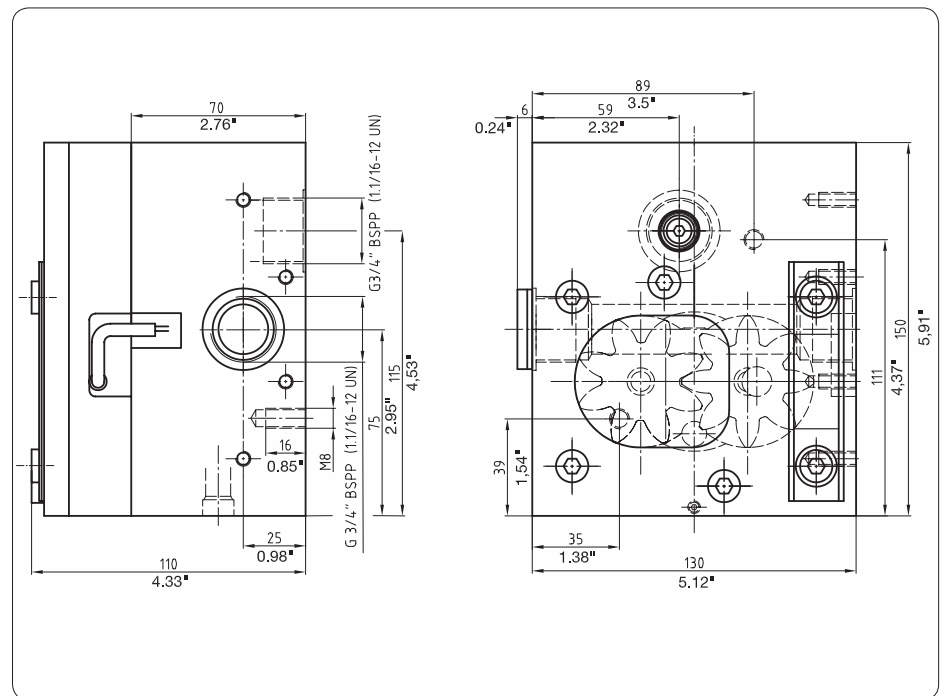

## Examples of SMD 1B / SMD 2 / SMD 3 in a stainless steel cabinet

Standard cabinets are available with 12, 30 or 40 lubricating points maximum. Arrangements and equipment (e.g. lamp) depending on customer specification.



stainless steel cabinet  
Dim. 600 x 600 mm  
with max.  
12 lubricating points;  
23.6"x23.6"

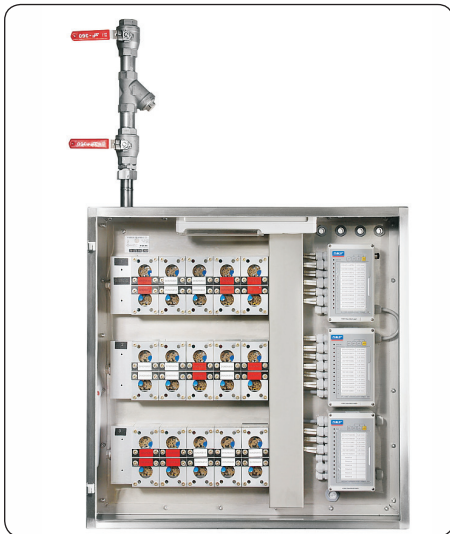
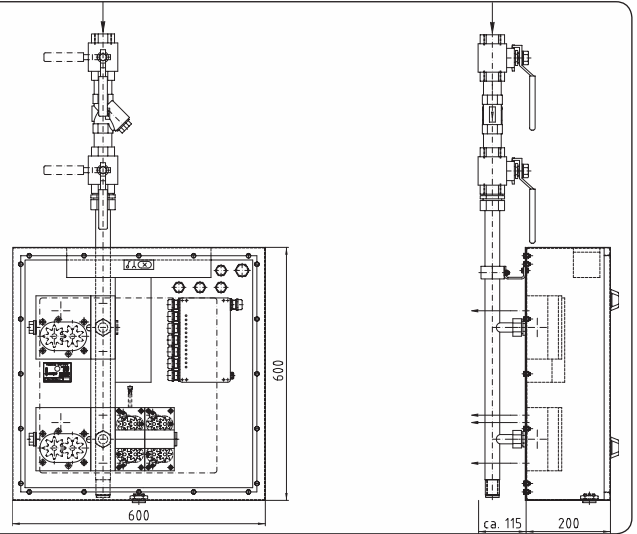

stainless steel cabinet  
Dim. 800 x 800 mm  
with max.  
30 lubricating points;  
31.5"x31.5"

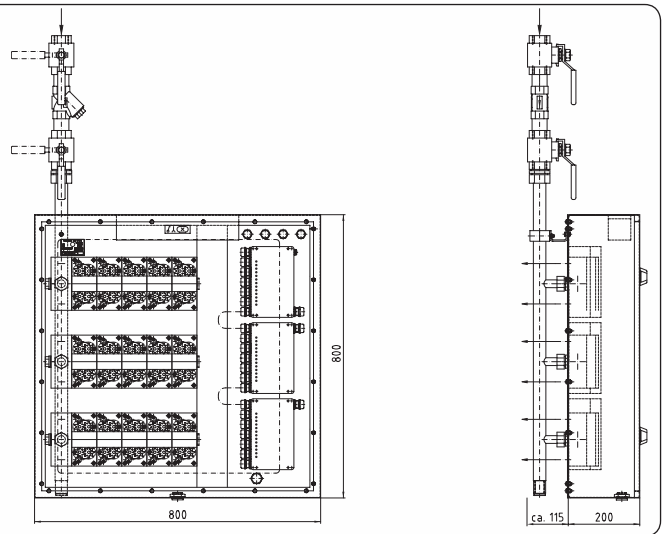

stainless steel cabinet  
Dim. 1000 x 1000 mm  
with max.  
40 lubricating points;  
39.4"x39.4"

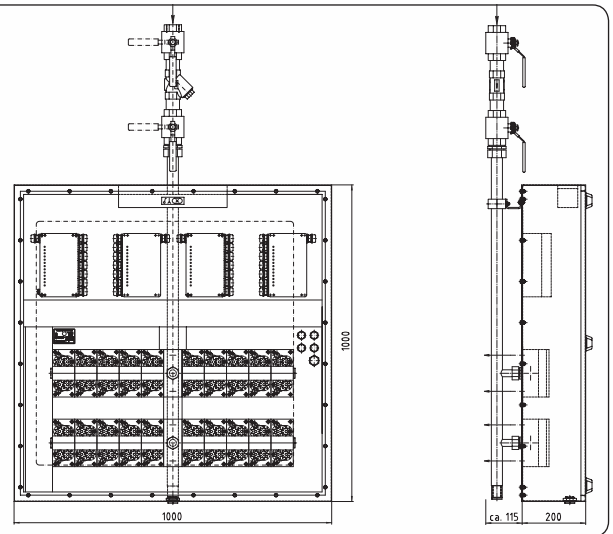

**Order list** (Stainless steel cabinet on request)

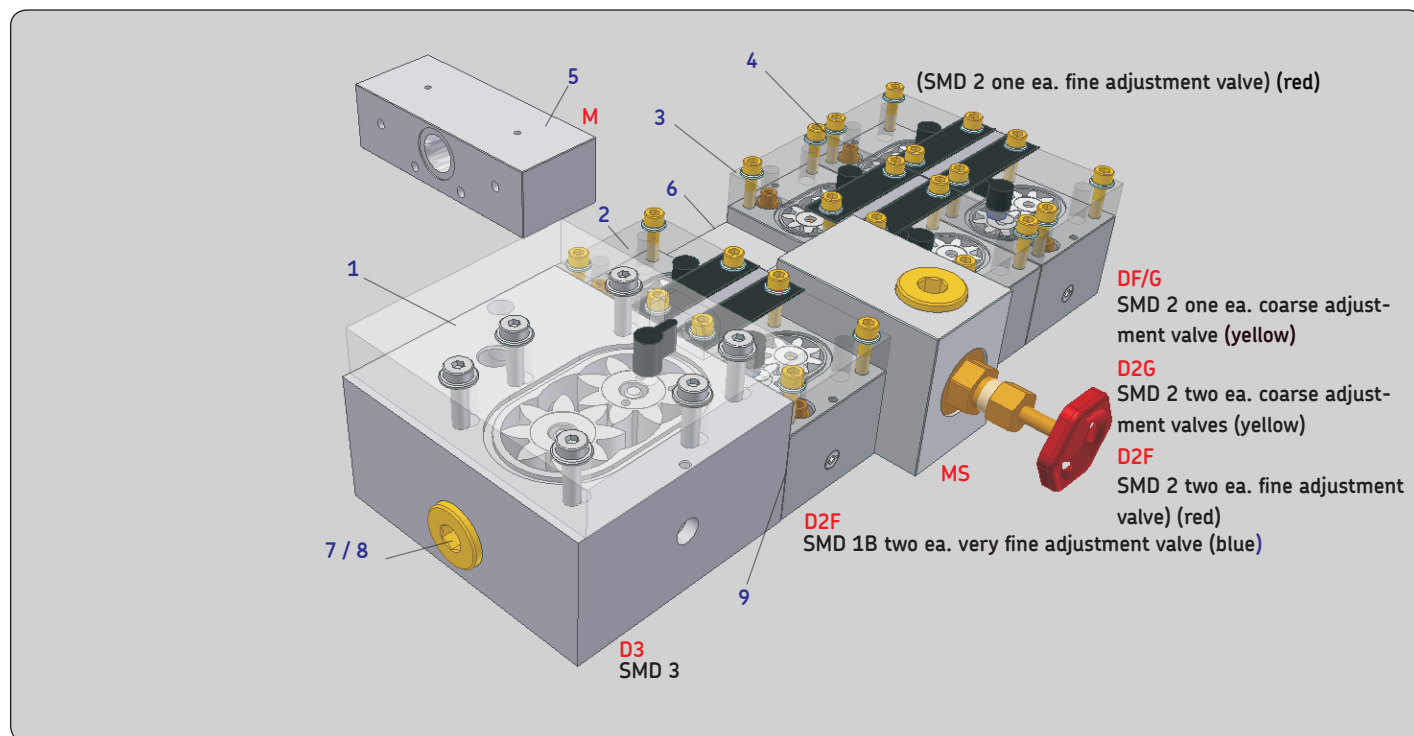

Item	Type	Designation	Symbol	Order No. Specification BSPP thread	Order No. Specification UN/UNF thread
1	SMD 3	Flow meter	D3	24-2581-2652	24-2581-2693
2	SMD 1B	Flow meter (2 ea. very fine adjustment valves)	D2F	24-2581-2650	24-2581-2651
3	SMD 2	Flow meter (2 ea. fine adjustment valves)	D2F	24-2581-2656	24-2581-2615
3	SMD 2	Flow meter (2 ea. coarse adjustment valves)	D2G	24-2581-2657	24-2581-2617
4	SMD2	Flow meter (1 ea. fine adjustment valves (top)) and 1 x coarse adjustment valves (down))	DF/G	24-2581-2658	24-2581-2616
5	SMD 1B/SMD2	Complete connection block	M	24-1503-2103	24-1503-2104
6	SMD 1B/SMD2	Complete shut off block	MS	24-1503-2102	on request
7		Plug screw 3/4" BSPP DIN908 (1.1/16-12 UN)		95-0034-0908	24-1855-2029
8		Gasket A27x32 DIN7603 Cu		95-2721-7603	
<b>Replacement parts</b>					
	SMD 1B	Set of replacement parts		24-9909-0184	24-9909-0184
	SMD 2	Set of replacement parts		24-9909-0178	24-9909-0178
	SMD 3	Set of replacement parts		24-9909-0179	24-9909-0179
	SMD 1B/SMD 2	Seal kit		24-0404-2520	24-0404-2520
	SMD 3	Seal kit		24-0404-2521	24-0404-2521
<b>Mounting screws</b>					
9	SMD 3	Mounting screw (4x)	DIN912-M6x45-8.8D2R	DIN912-M6x45-8.8D2R	
9	SMD 1B/SMD 2	Mounting screw (4x)	DIN912-M6x60-8.8D2R	DIN912-M6x60-8.8D2R	
<i>Mounting screw included in delivery of SMD 1B und SMD 2 !</i>					

**Order No. 1-3021-EN**

Subject to change without notice! (07/2014)

**Important product usage information**

All products from SKF may be used only for their intended purpose as described in this brochure and in any instructions. If operating instructions are supplied with the products, they must be read and followed.

Not all lubricants are suitable for use in centralized lubrication systems. SKF does offer an inspection service to test customer supplied lubricant to determine if it can be used in a centralized system. SKF lubrication systems or their components are not approved for use with gases, liquefied gases, pressurized gases in solution and fluids with a vapor pressure exceeding normal atmospheric pressure (1013 mbars) by more than 0.5 bar at their maximum permissible temperature.

Hazardous materials of any kind, especially the materials classified as hazardous by European Community Directive EC 67/548/EEC, Article 2, Par. 2, may only be used to fill SKF centralized lubrication systems and components and delivered and/or distributed with the same after consulting with and receiving written approval from SKF.

**Leaflets**

- 951-130-300-EN Operating manual SMD 1B/SMD 2/SMD 3 - lubricating system VARIOLUB
- DSB 6-015-09-EN Operating manual for VARIOLUB (with Handheld display and PGA 2)
- 951-130-310-EN Operating manual for VARIOLUB (with PGA 3)

**SKF Lubrication Systems Germany GmbH**

2. Industriestrasse 4 · 68766 Hockenheim · Germany  
Tel. +49 (0)62 05 27-0 · Fax +49 (0)62 05 27-101  
[www.skf.com/lubrication](http://www.skf.com/lubrication)

<b>This brochure was presented by:</b>

® SKF is a registered trademark of the SKF Group.

© SKF Group 2014

The contents of this publication are the copyright of the publisher and may not be reproduced (even extracts) unless prior written permission is granted. Every care has been taken to ensure the accuracy of the information contained in this publication but no liability can be accepted for any loss or damage whether direct, indirect or consequential arising out of the use of the information contained herein.

